



TR250 - TR6 Carburetor Overhaul Part I - Disassembly & Theory

These notes were initially prepared and published as a three part series in the Buckeye Triumphs Newsletter in late winter & early spring of 2001 and then placed on the Buckeye Triumphs website. Over the next six months input and useful suggestions were received from a number of folks. I also rebuilt several more carb sets and realized that the information could be clarified in a number of places. The carbs originally described in these notes were powder coated, which required the carbs be taken apart again and further disassembly of the temperature compensators, bypass valves and float chamber vent valves. Some problems were encountered tuning the powder coated carbs. These problems caused a review the previous suggested tuning procedures. Turns out the procedures were correct, the problem was in another area of the engine. I decided to revise the notes to work in the additional information, corrections and suggestions and add parts describing how to powder coat the carbs and how to install adjustable needles in the early non-adjustable carbs. Hopefully someday I'll be able to add a part describing how to replace the throttle shaft bushes and a part on the use of exhaust gas sensors. NAR 11/2001.

Another update: I built an air/fuel monitor and used it to tune the carbs described in Parts I, II & III. The use of the monitor provided considerable insight into the operation of the carbs. However, the optimum adjustment determined from using the monitor was the same as determined earlier without the monitor (see Part III). The monitor is described in the accompanying notes [Air/Fuel Monitor](#) and [Using an Air/Fuel Monitor](#). NAR 12/22/2001

It's early February; too cold to do much work in the unheated garage and the '76 TR6 is off to the painter anyway. I started the TR250 about a month ago and noticed that the rear carb was leaking. That's happened before ---- a sticking needle valve in the float chamber. About two weeks ago the BTWebmaster received an email from someone who started their TR6 after it had been setting for a few months and noticed one of the carbs was leaking. This week an acquaintance emailed with questions about a leaking carb. All these leaking carbs --- I got to thinking maybe I should take a look at the carbs on the '76TR6 before I reinstall them. After inspecting the carbs I realized they are a later design intended as universal replacements. I then decided to get the original carbs out of storage, rebuild them and install them on the engine. Since I have the time I decided to document everything for others who might want to work on their carbs.

Before we start, a few comments about the Zenith-Stromberg 175CD carbs are in order. CD is an abbreviation for Constant Depression. The meaning of depression in this context isn't the despair you feel when the spouse buys a \$500 frock. Nor does CD refer to the hopelessness some folks feel about the carbs. Depression in this context refers to a lowered air pressure, usually as compared to normal atmospheric pressure. The term *tropical depression* is a similar usage. The CD carb is designed to have a near Constant Depression in the mixing chamber and over the fuel jet. The meaning of this and how it works is discussed later.

Many folks complain about the carbs and are always adjusting them. In some cases the adjustment screws have been turned so many times the threads in the aluminum parts have been worn out --- stripped. I've found that the carbs very reliable (except for sticking needle valves) and are relatively insensitive to many of the adjustments. One might ask -- why do folks keep adjusting them. One answer might be that the folks are trying to compensate for poor compression (rings or valves), partially plugged fuel lines or filters, or ignition problems. One friend says as a rule of thumb, 90% of all carb problems are ignition related. If one is about to undertake a carb rebuild to fix poor performance, it's probably a good idea to make sure that the problem is really in the carbs. For example, I recently overhauled and reinstalled a set of carbs. Everything was running perfectly. I then pulled the plugs to check the compression. After I put everything back together I noticed an occasional misfire, black smoke from the pipes and a black soot on the rear bumper. Carb problem???? No way. I put the timing light pickup on each plug wire and found number two occasionally misfiring. Pulled the plug and found it was black (as expected) and also found that the gap was about 0.005". Then I remembered dropping one of the plugs -- must have been this one. Pulled the other five again and made sure gap was proper --- it was. It was interesting that all were pretty black even though only one plug was acting up. After fixing the gap on the one plug took a seven mile drive and then pulled a couple plugs from the front three and a couple from the back three and found all had the proper light brown color.

Many have noted that a Triumph is second only to a woman as a money pit. (I'm fortunate that the wife is an excellent manger allowing my three TRs to be the major money pit). However, fixing something that ain't broke is a real waste of these funds. My guess is that a significant percentage of TR repairs, maybe half, are to fix things that ain't broke. I have two strong suggestions, first, don't show this to the wife, and second, try to make sure that a repair is actually required before spending the \$\$\$.

Carb Variations

These notes apply to TR250 and TR6 carburetors. They may also apply to other Triumph models that use the same or similar carbs.

The carbs used on the TR250 through the '76 TR6 are nearly identical. The TR250 and early TR6 carbs had fixed metering needles (carb models C3150 & C3292). The changeover to adjustable metering needle was made during the '70 model year. (I wasn't aware of the fixed needle variation until researching this article. My TR250 and early '70 TR6 both have the adjustable meter needles. Apparently a previous owner had upgraded the carbs, at least on the TR250.) There are numerous variations in the ports used to connect vacuum lines through the years. An emission breathing port was introduced on the '70 TR6 and a float chamber emissions vent port was introduced in 1973. The return spring on the cold start valve (choke) was discontinued in 1974, which in turn required the use of stiff wire rather than flexible choke cables. TRF catalogues are a good reference illustrating the variations between models and year of manufacture. The metal tag under one of the top cover screws list the specific model that can be matched to the TRF catalog. The following summarizes the major characteristics of the various models.

General Carburettor Characteristics					
Carb Tag	Carb Model	Application	Needle	Adjustable Bypass Valve	Choke Spring
C3150 L/R	175CD-2SE	TR250, '69 TR6	B2Y-Fixed	Varies	Yes
C3292 L/R	175CD-2SE	'70 TR6	B1AF-Fixed	Yes	Yes
C3365 L/R	175CD-2SE	'70 TR6	B1AF-Adj	Yes	Yes
3385 L/R	175CD-2SE	'71 TR6	B1AF-Adj	Yes	Yes
C3337 L/R	175CD-2SE	'72 TR6	B1AF-Adj	Yes	Yes
C3508 L/R	175CD-2SEV	'73 TR6	B1AF-Adj	Yes	Yes
C3613 L/R	175CD-2SEVX	'74 & '75 TR6	B1AF-Adj	Yes	No
C3771 L/R	175CD-2SEVX	'75 & '76 TR6	B1AF-Adj	Yes	No

Carburettor Ports									
Carb Tag	Application	Emission Breathing Ports	Float Chamber Emissions Vent Port	Vacuum Ports					
				Bypass Valves	Top Covers	Rear Carb Near Manifold		Front Carb Near Manifold	
						Top	Bottom	Top	Bottom
C3150 L/R	TR250 & '69TR6	No	No	Yes	No	Yes	No	No	No
C3292 L/R	'70 TR6	Yes	No	No	No	No	Yes	Yes	No
C3365 L/R	'70 TR6	Yes	No	No	No	No	Yes	Yes	No

TR250/TR6 Carbs Part I

C3385 L/R	'71 TR6	Yes	No	No	No	No	Yes	Yes	No
C3337 L/R	'72 TR6	Yes	No	No	No	No	Yes	No	No
C3508 L/R	'73 TR6	Yes	Yes	No	No	No	Yes	No	No
C3613 L/R	'74 & '75 TR6	Yes	Yes	No	Yes	Yes	Yes	No	Yes
C3771 L/R	'75 & '76 TR6	Yes	Yes	No	No	Yes	No	No	Yes

The overhaul described in the following consists of taking the carbs apart, cleaning thoroughly and then reassembly with new float valves, throttle spindle seals, and gaskets. The carbs are then reattached and tuned. Those of you that are having trouble with leaking gas and don't want to rebuild the entire carb should refer the sections on disassembling and reassembling the float chamber in Part II.

The version of the 175CD carbs used on the Triumphs have only a few adjustments, many less than the versions used on some other cars of the period. We'll discuss these adjustments (carb tuning) in Part III.

Carb Removal

No special tools are required to remove and disassemble the carbs. (However, two special tools discussed in Part III are required to tune the carbs.)

There are two ways to remove the carbs. One or both carbs can be removed from the intake manifold on the engine or the manifold with the carbs intact can be removed and placed on the bench and then the carbs removed from the manifold. Whichever way you choose, you have to face the task of using an open-end wrench to remove the carb from the manifold since there is insufficient clearance to use a socket.

The first step is to disconnect the choke cable. Use needle nose pliers to hold the swivel through which the inner cable threads and loosen the screw sufficiently to free the cable. The screw is shown in the left photo below. Once the screw is loose, remove the clip retaining the cable to the upper part of the carb. The fuel and emission breathing hoses and vacuum hoses are then disconnected.

Next, the screw securing the spring coupling to the throttle shaft on the carb to be removed is loosened with a ¼ nut driver (see right photo below) and the coupling is slid off the shaft.

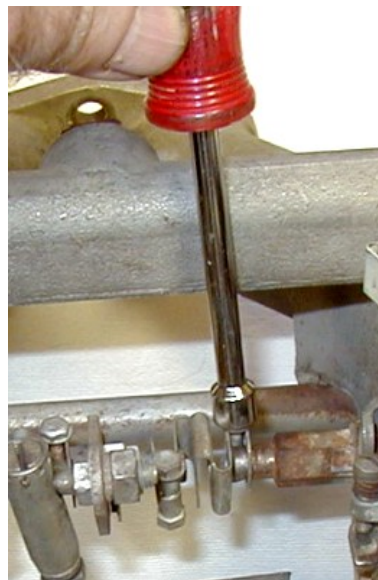

Four studs hold each carb to the manifold. The throttle linkage support bracket shown in the next photo is mounted on the lower inside stud of each carb and must be removed before either carb can be removed. The remaining three nuts on each carb are then removed and the carbs lifted off.



Disassembly

It is recommended that only one carb be disassembled at a time. This prevents mixing parts and assures that you have a model should you have trouble figuring how to reassemble the carb.

The first step is to clean up the carb. I apply degreaser, then detergent and then rinse with hot water. You all may wonder why I spend so much time cleaning the stuff before I work on it. This work is done in the basement where the cats live. Since they crawl over everything, I'm concerned that they might track the grease all over the shop. Further, I like to snack while working and a dirty carb adds new meaning to the term *greasy potato chips*.

I then clean the carb again with solvent to remove the varnish like coating. (Remember that the carbs are located above the exhaust manifold so this stuff is literally baked on. Fortunately, the carbs set out a little from the exhaust so the leaking gas doesn't drip on the hot exhaust system.) I use lacquer thinner. **Caution, lacquer thinner is very volatile and breathing the fumes is harmful. Read the warnings on the container.** A couple inches of thinner in a 39 oz coffee can makes an excellent parts bath. The plastic cover seals off the fumes when not in use (don't want the cats injured by the fumes). The entire carb is too big to put in the can but can be held over the can and the thinner applied with a small brush.

TR250/TR6 Carbs Part I



The top cover is removed first. A local teenage Triumph enthusiast commented one time that the screws in the top cover are not Phillips head but some other type and may be damaged with a Phillips screwdriver. I told him that was new to me. While looking up parts in a recent Moss catalog I found a note describing the screw heads as Posidrive and a recommendation that a Positive screwdriver be used to remove the screws. The Phillips worked fine but it shows I should listen to the young folks.

When the top of one carb was removed a note (in my writing) dropped out saying that oil leaks out of the damper. We'll get back to that later. The previous photo shows the air valve return spring sticking out of the air valve. The adjacent photo shows the air valve being removed. These parts are then cleaned with the thinner. Don't let rubber components such as the diaphragm soak in the lacquer thinner --- it might dissolve it --- the same for rubber seals and plastic parts. The screws are kept together with the top cover and set aside till later.



Next, the carb is turned upside down and the sealing plug is pried out of the float chamber with a screwdriver blade and then the six screws are removed and the float chamber lifted off. The floats are then pried out of the retaining clips. The photos show this work. The parts are then cleaned in the thinner. Avoid leaving the plastic floats in the thinner for an extended period. Note: early carbs have a brass plug with a screwdriver slot that is removed by unscrewing it.

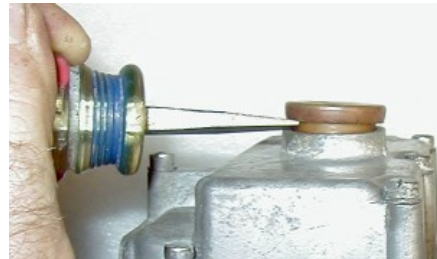

The throttle spindle (shaft) is attacked next. **The disk and spindle shouldn't be removed unless replacement of the spindle seals is anticipated.** The two screws securing the throttle disk are removed. The screws are copper and are difficult to remove because the ends have been spread to prevent them coming out in normal use. Be sure to use a slotted screwdriver with a blunt end and try to avoid damaging the head. After the screws have been removed, rotate the throttle spindle about 90 degrees and slide the disk off the spindle as shown in photo.

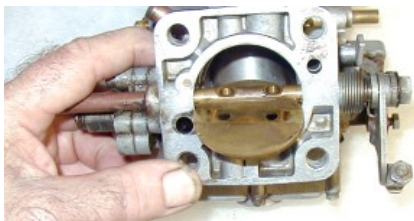

Next, use a small file to smooth any burrs from the screw holes to prevent damage to the spindle bushing and seals when the spindle is removed. The spindle is then slid out. The disk is put back on the spindle and screws reinstalled loosely on the shaft so the parts won't become separated.

Removing the small subassemblies

Next, three small sub assemblies and the idle trim screw are removed from the main body. Each is cleaned in thinner after it is removed and set aside together with the associated screws. The following photos show this process.

Removing the cold start valve (choke).



Removing the Temperature Compensator: one screw on each side and then pry out. Be sure to not lose the two fiber washers, one around the part that extends into the body and the other at the bottom of the hole in the body. These washers are not included in some rebuild kits.



Removing the Bypass Valve: the three slotted screws.



Removing the idle trim screw.

All the nice clean parts:

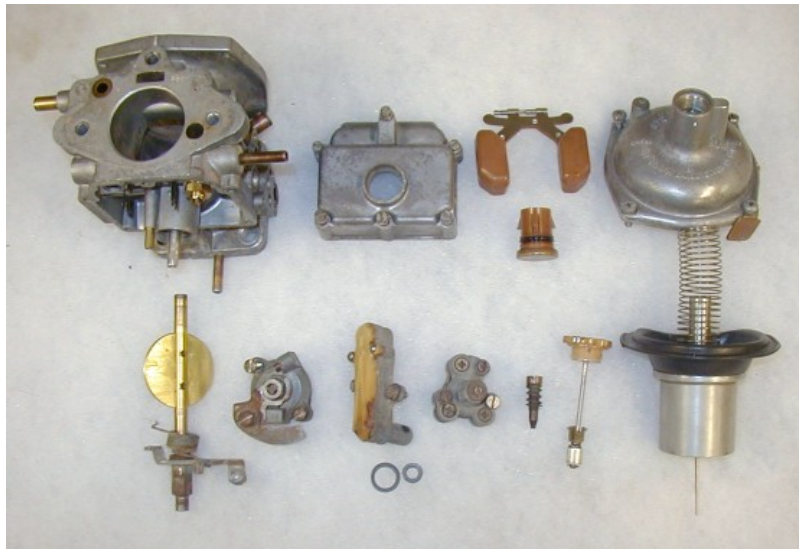

So, how does the carb work?

Being an engineer and teacher, I just can't help lecturing a bit on these little beauties; fine examples of precision engineering and manufacturing. This discussion was deferred until the major components have been shown in photos.

The next sketch is taken from the Haynes manual and shows the cross section of the carb body. Recall that the job of the carb is to mix air and fuel in exactly the correct proportions as required by the engine. Also recall that the carb connects to the engine intake manifold. The engine creates a depression in the intake manifold as it sucks the fuel-air mixture into the cylinders. In response to this depression, air is sucked into the carb on the left side of the sketch, flows over the bridge where fuel is sucked out of the jet and mixed with the air and then past the throttle plate into the intake manifold.

TR250/TR6 Carbs Part I

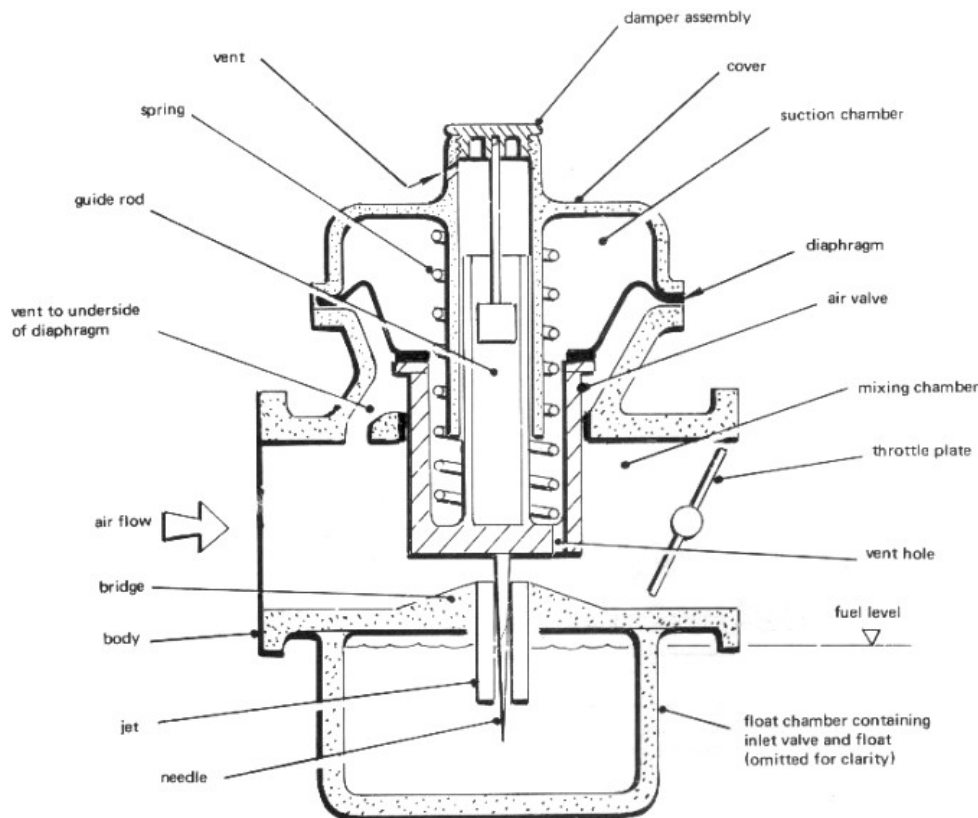

The air increases in velocity as it flows through the constricted area above bridge. The airflow creates a depression on the sides of the constricted area. This depression makes the air pressure over the jet less than the atmospheric pressure on the fuel in the float chamber. The higher atmospheric pressure pushes fuel up through and out of the jet. (Another way to say this is that the depression over the jet sucks the fuel out of the jet.) This process of fluid flow past an open jet sucking out another fluid is called venturi action and is also the principle used in spray guns, siphon sandblasters, and perfume atomizers.

The amount of fuel sucked out of the jet is controlled by the fuel level, the area of the opening between the jet and the metering needle and the velocity of the air moving past the jet. The fuel level in the float chamber is kept at a constant level by a float-controlled valve. The jet and metering needle are precision components manufactured to close tolerances. If the throttle plate is opened, the velocity of the air going by the jet will increase substantially and too much fuel will be sucked out of the float chamber producing a much too rich mixture.

The system is designed to keep the velocity of the air over the jet and hence the depression at the end of the jet nearly constant as the throttle opens and closes, thus the name Constant Depression or CD. This is accomplished by raising the air valve (that big piston shaped thing) to enlarge the cross sectional area for the air to pass allowing more air to pass at the constant velocity. More fuel is required to mix with the additional air to keep the air fuel mixture at the correct value. The tapered metering needle attached to the bottom valve of the air valve accomplishes this. As the air valve moves up the tapered needle is withdrawn from the jet increasing the open area between the needle and the jet. This is similar to opening a faucet. Let's go over that again: the throttle opens, the air valve moves up and we get more air and more fuel ---- just what the doctor ordered! It is no small engineering and manufacturing feat to make all this work such that the correct fuel-air mixture is delivered over a wide range of engine speeds and loads.

Now, what makes the air valve move up when the throttle is opened? There is a diaphragm attached to the top of the air valve, which together with the cover and the inside of the air valve form a suction chamber. There is a vent hole in the bottom of the air valve connecting the suction chamber to the mixing chamber. When the throttle plate is opened, the air pressure in the mixing chamber drops and air is sucked from the suction chamber through the vent hole thus reducing the air pressure in the suction chamber. The under side of the diaphragm is maintained at atmospheric pressure via a vent on the air input side of the carb. The higher atmospheric pressure on the bottom of the diaphragm pushes the diaphragm up and the air valve with it. Offsetting the force lifting the valve is the weight of the valve and the force of the spring. As the air valve rises, the depression in the mixing chamber reduces, reducing the depression in the suction chamber. At some point, the forces caused by the differing air pressures exactly offset the weight of the air valve and the force of the air valve spring and the air valve stops rising. It is very easy to observe this operation on a running engine with the air filters removed. When the throttle is opened, the air valve goes up, close the throttle, the air valve drops. You will also note that the control is proportional, the more the throttle is opened, the higher the valve goes. The depression over the jet is nearly constant for all stable positions of the air valve.

Now lets talk about oiling the carbs. Yes, these carbs require oil in the guide rod (that tube pressed into the air valve). The oil is added through the center of the top cover after the damper assembly is unscrewed and removed. The Haynes manual says to use Zenith lube oil. I've never seen it for sale. Other manuals have suggested regular engine oil. I prefer SAE20 3-IN-ONE electric motor oil sold in 8 oz cans. The guide rod should be filled to within about 1/4 inch of the top of the rod. After the oil has been added and the damper reinstalled, the air valve should be lifted (with your finger through the big opening to the air filter) to the upper most position. This allows excess oil to exit through the vent at the top of the cover (making a big mess) and positions the brass colored thimble like part on the damper assembly (next photo) into the top of the guide rod. The thimble, apparently provided only on the '75 & '76 carbs, must be in position to align the air valve and insure that it can move up and down freely.



While lifting the air valve you'll notice there is resistance to lifting it rapidly. (You can try this on the carb you haven't disassembled. If there is little resistance, try adding oil.) You'll also notice that that when released, the air valve drops quickly. When the throttle is opened, the damper slows the air valve rise causing increased velocity and increased depression over the jet sucking in more fuel and producing the richer mixture desired when accelerating. As the air valve rises, the depression and hence the mixture is leaned back to normal.

During deceleration, a process in reverse to the above takes place. When the throttle closes, the amount of airflow is reduced radically. If the air valve stays up, the velocity of the air over the jet drops to a very low value and the mixture is very lean. This can cause a slow burn in the engine resulting in popping back in the carb and explosions in the exhaust system (backfires). The air valve must drop very rapidly during deceleration to prevent the overly lean mixture and associated side effects.

Next question --- how come the air valve goes up slowly but drops rapidly? The answer is the design of the damper. There is a small clearance between the air guide and the little piston on the damper (the damper piston). The damper piston pressing against the oil in the bottom of the air guide prevents the air valve from rising until some oil squeezes by the damper piston into the upper part of the guide rod. If the lifting force to the air valve is maintained the oil will slowly flow by the damper piston allowing the valve to rise slowly. The valve is much less restricted when dropping because of the design of the piston. The hole on the inside of the damper piston is much larger than the damper rod. The piston is also free to move up and down on the rod a short distance between a beveled stop on the top and a C ring on the bottom. When the air valve is dropping the little piston moves to the lower position on the rod. In this position oil can flow relatively freely between the inside of the damper piston and the rod allowing the air valve to drop quickly. Note that when the valve is moving up, the damper piston moves to upper position on the rod. In this position, a beveled washer on the top of the piston rests against the beveled stop sealing the passage between the inside of the piston and the rod. Neat huh?

Fixing the Leaks

Remember, I got started on this because of the leaking carbs. The float chamber has a needle valve and float that work together to maintain a constant level of fuel in the chamber similar to the float and valve in a toilet tank. When the level is too low the float allows the needle valve to open letting more fuel into the chamber. As the chamber fills, the float rises causing the needle valve to close when the fuel is at the correct level.

The major cause of leaks is the needle valve not closing when the chamber is full allowing it to overflow. The two other sources of leaks are the float chamber gasket and the O-ring around the sealing plug in the bottom of the chamber.

The typical leak starts after the car has been setting for many months. When setting for a long period some of the fuel evaporates from the chamber causing the float to drop and the valve to open. It's likely that a residue on the valve left from the evaporation prevents the valve from closing when next used.

Often the leak from the stuck needle valve can be fixed without removing and disassembling the carb. The first thing to try is to rap the float chamber with the handle of a medium sized screwdriver several times.

If the rap doesn't work, one can try pulling the sealing plug and draining the chamber. Next, insert a small wire such as a straightened paper clip through the plug hole and **gently** move the floats. You have to do this by feel since you can't see what is going on. Next, disconnect the fuel line at the carb and spray carb cleaner into the fuel input tube. The needle valve is at the end of this tube. Hopefully the cleaner will dissolve any deposits that are preventing the valve from closing. After letting it set for 30 minutes or so reinstall the plug and fuel line, cross your fingers and test it.

If the above procedure fails to fix the leak then the carb must be removed and the float chamber opened. Once you've gone that far, it is probably a good idea to replace the valve as described later.

Float Chamber Vent

The air above the fuel in the float chamber must be maintained at atmospheric pressure for the carb to work properly. There is a passage in the main casting from the float chamber to the air filter assembly to allow free air flow. The photo at the right shows the port where it connects to the air filter assembly. Note that the vent in the photo has a brass sleeve used on '73 and later carbs. The early carbs have a plain hole in the casting that leads to the float chamber.

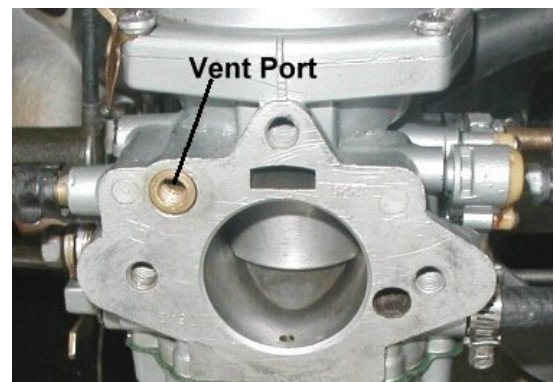

Float Chamber Vent Valve

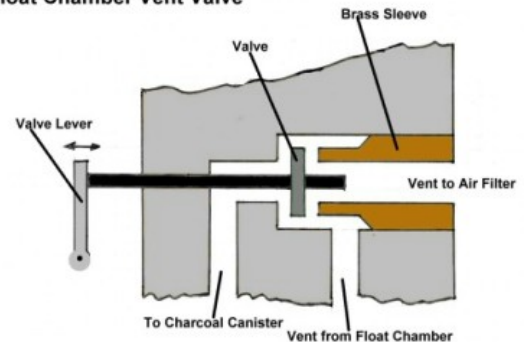

Float Chamber Emissions Port

A valve was installed in the float chamber vent path of '73 and later TR6s as shown in the sketch on the right.

When the throttle is in the idle position, the valve is pushed to the right against the brass sleeve, which blocks the vent to the air filter. The float chamber is vented to the carbon canister when the valve is in this position (idle). This serves to collect any vapors that escape from the chamber when the engine is not running.

When the throttle is advanced, the valve moves to the left opening the vent path to the air filter and closing the path to the canister. This makes the operation with the throttle off idle the same as without the emissions connection.

The middle photo shows the actual valve components. The brass sleeve is on the right. The white disk is the valve. The springs, not shown in the above sketch, push the valve to the right when the throttle is at idle and push the valve to the left as the throttle moves off idle.

The lever that operates the valve is shown in the last photo. The adjustment of this lever is discussed in Part II. The vent is also used in conjunction with the anti run-on valve to eliminate dieseling also discussed in Part II.

We start the reassembly in Part II.



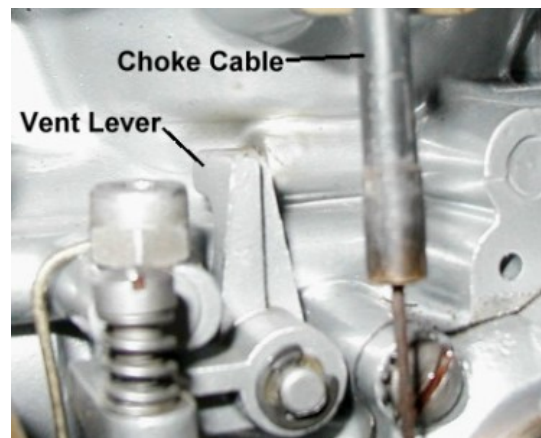

Repair Parts

A few words are in order about parts before we get into the overhaul. Both TRF and Moss carry most carburettor maintenance parts. If one is doing a complete overhaul then the TRF major rebuild kit ZEMS577 listing at \$26 per carb is probably a good choice. One thing that you'll definitely want to consider if the carb has been leaking gas is to replace the needle valve in the float chamber. One problem I've always had with the kits is that they contain about three times as many parts as needed (last one purchased about 10 years ago). With all the extra parts you're not sure you're using the correct part and you wonder if you're using all the parts you should. I think (make that hope) the extra parts are used on different models for different applications. The following shows the extra parts from 6 kits.



If you're only worried about fixing a leaking carb, then at most you only need a new valve, float chamber gasket and O-ring for the plug in the float chamber. Bought separately, they cost about half as much as the kit. Both TRF and Moss sell the Grose Jet after market needle valve replacement for about \$6. I much prefer the Grose Jet because I believe it is less prone to sticking. TRF major rebuild kit ZEMS577 normally contains the Grose Jet. Unfortunately, the manufacturer quit shipping the Grose Jets about a year ago and neither TRF nor Moss have any in stock. So, for now, it's the old style needle valve.

If one is working with 1974 or later carbs that use the stiff choke cable, consideration should be given to purchasing springs (Moss carries them) and modifying the cold start valves (choke) so that the more reliable flexible choke cable can be used. See the discussion under the cold start valve.

If one is doing a complete rebuild for the first time then the throttle spindle (shaft) seals should be replaced. TRF sells the neoprene seals alone for \$1.50 each or the seals with metal shell for \$9.50 each.

Many of the non-wear carb components are no longer available so one should not pass up the chance to purchase one or a pair of old carbs for spare parts. One might ask, "If they're non-wear parts, why do you need the spares?" The answer is that when amateur mechanics take the carbs apart, we sometimes loose parts (the cat drags it off) or we break them because we don't know how to take them apart (or we don't own a Positive screwdriver).

We do the overhaul in Part II and install and test the carbs in Part III.