

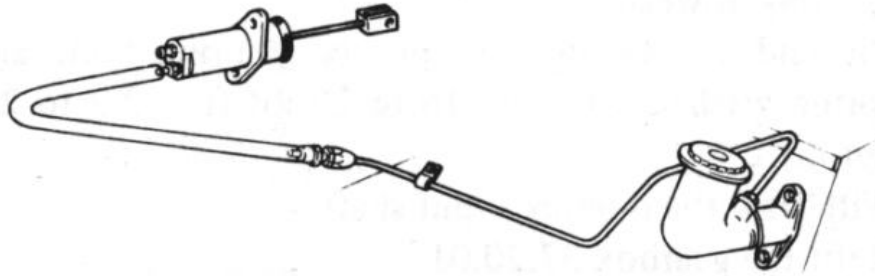

TR250/TR6 Clutch Hydraulics Overhaul

TR250s and TR6s use hydraulics to transfer the clutch pedal motion to the clutch-operating shaft in the front of the gearbox. The system is nice in that it is self-adjusting and requires little maintenance except for occasionally checking the fluid level in the master cylinder reservoir. The sketch below shows the basic system. (The sketches are from a TR6 Maintenance Manual.) The clutch pedal connects to a piston in the master cylinder (on the right). When the pedal is pressed, the piston in the master cylinder is pushed in forcing hydraulic fluid from the master cylinder through the tube and hose to the slave cylinder (on the left). The fluid pushes the slave cylinder piston toward the open end of the cylinder pushing the push rod that connects to the lever on the clutch-operating shaft that in turn releases the clutch.



The major wear components in the hydraulic system are the rubber seals in the cylinders that prevent the hydraulic fluid from escaping past the pistons as the clutch pedal is pressed. The first sign that the seals are leaking is usually a puddle of oil on one's left foot or on the carpet under the clutch pedal (leaking master cylinder) or a puddle under the left rear of the engine from a leaking slave cylinder (you must be careful to differentiate a puddle of hydraulic fluid from the puddles of engine and transmission oil that are usually under a Triumph). Another sign that the seals are leaking is a reduced fluid level in the reservoir. (Hopefully you detect the failing clutch before the pedal becomes soft and fails to operate the clutch when you're 200 miles from home in a thunderstorm.)

One thing I've noticed is that the fluid in the reservoir turns black when the seals are about to fail. After about ten years the seals seem to dissolve in the fluid; I've suspected that planned obsolescence is at work here.

The following describes how to refurbish both the master and slave cylinders on a TR250 or TR6. The directions probably also apply to most other models. You'll see that the task is well within the capability of almost anyone possessing a little energy and a couple monkey wrenches.

My experience has been that the slave cylinder fails first (probably because it is the hardest one to get at). However, whichever has failed, it's likely the other is not going to last much longer. Therefore, it is suggested that when working on the system, both cylinders be pulled and refurbished at the same time.

Note: If the clutch is not operating properly but there is no sign of leaking fluid, the problem is most likely not the hydraulic system. You might want to check out some of the suggestions at the end of the article.

Draining the system

The first thing to do is to drain the hydraulic fluid from the system. This will minimize fluid leaking onto the body under the master cylinder when it is removed. (If you haven't noticed, mineral-based (DOT3 – DOT4) hydraulic fluid is a very effective paint remover.) I use a short plastic hose and an old plastic radiator overflow bottle as shown in the sketch. Connect the hose to the bleed nipple on the slave cylinder (#3 in sketch) and then open the nipple (7/16 wrench). Next, pump the clutch pedal until no more fluid exits from the slave cylinder. Care should be taken to make sure that the hose stays connected to the bleed nipple and the other end stays in the bottle to avoid squirting the fluid all over the place ---- **THINK: Paint Remover in a squirt gun.** The end of the hose should be above the level of the fluid in the bottle to prevent sucking fluid back into the cylinder when the pedal is released.

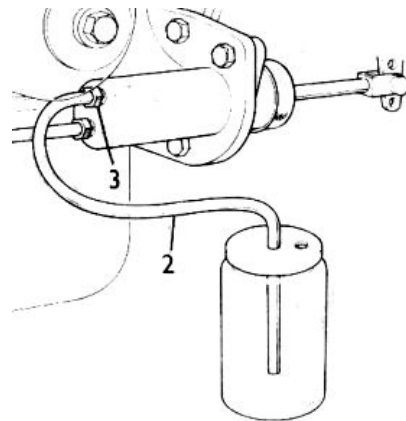

Removing the Cylinders

Start by unscrewing the steel pipe from the master cylinder (number 3 in the sketch). This requires a 1/2 inch wrench. You may want to hold a large rag under the master cylinder while doing this to catch any fluid dripping from the pipe. The clevis pin connecting the push rod to the clutch pedal arm is removed next (not shown in the sketch). You have to crawl under the dash ---- a hard one for us well fed old guys to get at. The two mounting bolts (#4 in sketch – 1/2 inch wrench) are then removed and the master cylinder lifted out.

The push rod between the slave cylinder and the clutch operating shaft arm is removed after the cotter pin in the clevis pin and the clevis pin is removed. The two bolts on the slave cylinder are removed (1/2 inch wrench) permitting the slave cylinder to be removed with the hose and steel pipe still attached. The hose can then be unscrewed from the cylinder.

Clutch Hydraulics

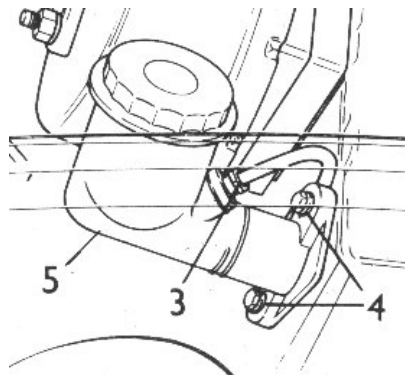

Next, all the parts are cleaned. I usually apply engine degreaser, rinse that off and then wash with hot water and hand cleaner or dishwashing detergent to get rid of the film from the degreaser. The inside of the pipe and hose should also be flushed. Finally, everything is rinsed off with hot water.

TR Lore

I bought a junk '76 TR6 about 20 years ago. It had been driven in the salt for several years so holes were rusted through the bumpers; big holes were rusted in the sills, the floorboards, and the lower part of the rear fenders were rusted off. My main interest was the J type overdrive and a good differential (I hoped). The young woman from who I purchased it said that she had had a lot of trouble with the clutch and finally gave up on it and let it set for a couple years. I paid \$200 for the car and another \$50 to have a wrecker drag it home.

When I checked out the slave cylinder I found that a stack of washers had been inserted on the bolts between the slave cylinder and the mounting plate to move the cylinder about a half an inch toward the rear of the car. The slave cylinder piston was missing and the push rod was hanging down from the clutch shaft arm.

Later, after the gearbox was pulled, the push rod was examined more carefully and found modified; it had been cut and a piece of tubing brazed in to lengthen it. This rod and a standard rod are shown in the following photo. Both these modifications suggest that the gearbox had separated from the engine and migrated toward the rear of the car. The actual problem was a broken clutch fork pin; the clutch wouldn't operate no matter how far the lever was pushed back because the fork rotated on the shaft.



Slave Cylinder Overhaul

We'll work on the slave cylinder first since it is the simplest. The first challenge is to get the piston out of the cylinder. If you're lucky, you'll be able to shake the piston out. That seldom works.

One can try forcing the piston out with compressed air. This should be done carefully because injecting compressed air into the cylinder converts it into a one hundred caliber missile launcher. First, close the bleed nipple. Next point the cylinder into a large wastebasket with impact absorbing material (loose trash) in the bottom. Next, push the air gun into the input port on the cylinder and trigger the air as shown in photo. In most cases the piston will fly out, especially if the cylinder has been in use recently.



If the piston doesn't come out, a little more work is required. Spray lubricant (WD40 works fine) into the cylinder through the input port and around the piston at the front of the cylinder. Then, use a punch and hammer to force the piston into the cylinder a half-inch or so. Clean the exposed inside of the cylinder with steel wool. Often, this area of the cylinder becomes corroded because it is beyond the point where the hydraulic fluid flows in normal operation. This area is especially corrosion prone if the cylinder has been out of service and stored in a damp area. The piston will now likely come out when compressed air is applied. Sometimes the piston will just move back to its original position at the front of the cylinder. If so, then it can be forced back, air applied again, etc. until it finally comes out. Be sure to not become lax about the target when the air is applied.

If compressed air isn't available, one can try to force the piston out with a small steel rod inserted through one of the two threaded holes in the closed end of the cylinder. This should be done carefully so that the spring is not damaged.

The slave cylinder components are shown in the following photo. Some older cylinders have a different type of piston that looks nothing like the one in the photo. The piston with rubber seal and the rubber boot are discarded --- the repair kit contains new replacements.

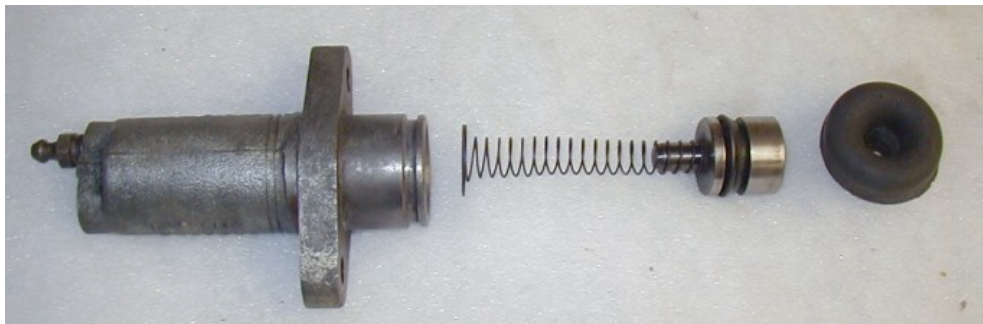

Clutch Hydraulics

The next step is to inspect the inside of the cylinder for corrosion, pits and other imperfections. The area of concern is from a depth of about ¼ inches to about 2 inches – the area where the rubber seal travels in normal operation. The last ¼ inch nearest the open end is prone to rust but not a major concern. This area can be cleaned with steel wool enough so the piston (with the rubber seal removed) passes freely. If the cylinder further in is smooth and shiny, as is likely if the cylinder has been in use recently, then no further work is required.

If the cylinder surface is not smooth and shiny, then a cylinder hone should be used. A hone is a tool with two or three small abrasive stones on spring-loaded arms that press against the inside of the cylinder. The hone is rotated with a drill to smooth the cylinder. Suitable small cylinder hones can be obtained at most auto parts stores. The following photos show a small hone and the hone in use. One should not be too concerned about the hone enlarging the diameter of the cylinder--- You can run it for hours without having much effect on the steel cylinder. If the hone is not able to eliminate all imperfections in a few minutes, one can try wrapping ~ 100 grit emery cloth around the end of the hone and rotating the emery cloth for a few minutes. If this doesn't clean up the cylinder, throw it out and buy a new one. If the emery cloth is successful, then the hone without the emery cloth should be used to remove the scratches caused by the 100-grit cloth.



Next, the bleed nipple is removed and cleaned as required. A wire or small drill bit can be used to clean dirt out of the center of the nipple. Engine degreaser should then be sprayed into the cylinder and a cloth forced into the cylinder and pushed around with a screwdriver to clean the rear of the cylinder. The two ports at the rear of the cylinder should also be checked to make sure they are clear. The parts should then be washed thoroughly and blown dry with compressed air (or a hair dryer if air is not available).

Once the cylinder is known to be good the rebuild kit can be purchased. I use The Roadster Factory (TRF) part number LDSSB629 usually purchased during the winter parts sale for about \$10. I also purchase a tube of Girling rubber grease, part number GISP 1230. One tube will probably last a lifetime if you don't misplace it. (There is a small packet of grease supplied with the master cylinder rebuild kit. There is sufficient grease in that packet for both the master and slave cylinder rebuilds.)



The first step in the rebuild is to put the new rubber seal on the new piston. Before doing this, apply a little rubber grease to the back of the piston to allow the seal to be slid on without damage. The largest part of the seal should be towards the closed end of the cylinder (front of the car) as shown in photo.

Next, the inside of the cylinder is thoroughly lubricated with fresh brake fluid. The small end of the spring is slid over the small end of the piston, the seal lubricated with rubber grease and then the spring followed by the piston slid into the cylinder. The piston should then be forced in and the last ½ inch of the inside of the cylinder should then be coated with rubber grease. This is the area that is corrosion prone because it is not lubricated by the hydraulic fluid. Installing the bleeder screw, putting the new rubber boot on the end of the cylinder and then inserting the push rod through the boot completes the rebuild. The completed cylinder is shown in the next photo. Oh, one more thing, the flexible hose and still connected pipe should be attached to the cylinder.



Master Cylinder Overhaul

The master cylinder overhaul starts with using small pliers to remove the circlip retaining the pushrod. These parts are shown in the next photo. The next step is to remove the piston. If it can't be shaken out then air is used in the same way described earlier for the slave cylinder. There is one difference; the air inserted into the output port goes to both the cylinder and the reservoir. The reservoir cap must be in place to allow pressure to build up in the cylinder. Unfortunately, pressure also builds in the reservoir. If the piston doesn't let go, the cap may blow off so we have a double-barreled missile launcher here. (The voice of experience speaking; fortunately, the cap has little mass so no damage was done when the cap hit the side of my head). Eye protection and care in the direction both barrels are pointed are in order. The removed piston assembly is shown in the subsequent photo.



Clutch Hydraulics



The cylinder inside surface is inspected to make sure it is clean and smooth. There is usually some corrosion near the open end of the cylinder. As with the slave cylinder, this area is beyond the travel area of the seal and can be readily cleaned with steel wool. I've never seen a damaged master cylinder so in most cases no honing is required. If honing is required, a small hone with light spring pressure should be used. Unlike the steel slave cylinder, the master cylinder is made of relatively soft aluminum and is easily scored with coarse abrasives. If the cylinder can't be made smooth then a replacement must be purchased. This hurts a bit. The new master cylinder costs about \$120 whereas the slave cylinder costs about \$45. If cylinder is to be reused, the inside of both the cylinder and the reservoir should be thoroughly cleaned and dried.

The piston assembly is taken apart next. A small screwdriver is used to pry up the tab on the spring thimble to separate the thimble from the piston as shown in the next photo. Some of the parts are under tension and subject to flying everywhere when the pressure is released so eye protection should be worn. It's also wise to work in a relatively clean and confined area so the parts can be retrieved easily. The disassembled piston is shown in the subsequent photo.



There are two types of master cylinder used on the TR250s –TR6s. The earlier one through 1969 has a 0.75-inch diameter piston and the later has a 0.7-inch diameter piston. The repair kits from TRF (early – part number GISP1967, later – GISP2102) cost about \$10 during the winter parts sale. The kits contain the gland seal (11), valve seal (9), wavy washer (between 7 & 8), circlip, boot and a small amount of rubber grease.

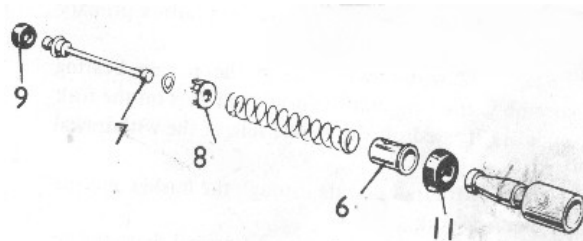

The parts to be reused should be cleaned thoroughly. Next a small amount of grease should be spread on the smaller end of the piston and the new gland seal (11) pushed on the piston. The larger part of the seal should be on the spring side of the piston as shown in the photo.

Next, the new valve seal (9) is slid on the valve stem (7). The new wavy washer is slid on the valve stem followed by the plastic spacer (8) and spring. The valve stem is then fed through the spring and hooked into the end of the thimble (6). The final step is to push the thimble onto the piston far enough for the tab to catch on the lip. It may be necessary to use the small screwdriver to bend the tab in a bit.

Lubricate the cylinder with fresh hydraulic fluid and the gland seal with a small amount of rubber grease. The piston assembly is then inserted into the cylinder, pushed in slightly and the end of the inside of the cylinder coated with a small amount of the rubber grease. The end of the pushrod and the washer are greased and a new boot is then installed on the pushrod. Some grease is squeezed on the cupped end of the piston and then the push rod is inserted into the cylinder and secured with the circlip. Finally, the boot is slid over the end of the cylinder completing the master cylinder overhaul.

Hydraulic Fluid

This is a good time to talk about hydraulic fluid. A purist might use the Girling LMA fluid available from TRF or Moss. In the past I preferred to use regular high quality brake fluid available at grocery and auto parts stores. Both these are mineral based fluids.

Another option is silicone brake fluid. The good point with the silicone fluid is that it is a less effective paint remover. The bad point is that it costs more than good quality whiskey. I'm having my '76 TR6 repainted at the present time. I just cleaned up the mess on the brake servo unit caused by a leaking brake MC and on the pedal assembly caused by a leaking clutch MC. One thing you can be sure of --- all Triumph hydraulic cylinders will leak sooner or later ---- more likely sooner, especially those near observable paint. So ---- I'm going to use only silicone fluid on my TRs from now on.

System Reassembly

The reassembly process is the reverse of disassembly. The master cylinder is mounted with the two bolts and then the clevis pin connecting the push rod to the pedal assembly is installed and secured with a washer and cotter pin.

The pipe and hose are fed through the hole in the slave cylinder mounting plate followed by the slave cylinder that is then secured with two bolts. Be sure to mount the cylinder such that the bleed nipple is at the top and the hose is at the bottom. The clevis is then inserted through the push rod and clutch-operating lever and secured with a washer and cotter pin. The last thing is to screw the steel pipe fitting into the master cylinder output port.

Bleeding the System

Clutch Hydraulics

The final task is to fill the system with hydraulic fluid and then bleed the air from the system. Connect the hose and bottle used for draining the system to the bleed nipple, put enough fluid in the bottle to cover the end of the hose, and then open the nipple about 1/2 turn. Fill the reservoir with fluid and screw on the cap (to prevent the fluid from splashing out). Pump the pedal several times until some fluid exits the tube into the bottle. Refill the reservoir as required. One can use this method to completely bleed the system – just pump the pedal until no more air exits the end of the hose and then close the bleed nipple while the pedal is still depressed – use a stick to hold the pedal down. I've always had trouble getting that last bit of air out by this method and the clutch will not operate properly if there is air in the system.

I prefer to call on the significant other for help here. Position her in the driver's seat and then jack up the left side (of the car) so you can crawl under it (remove the keys so she doesn't get any ideas about life insurance). I also secure the frame with jack stands as a backup. Get a 7/16-inch wrench and crawl under the car. Close the bleed nipple. Have her pump the clutch several times and then hold the pedal down (be sure to calmly tell her that the clutch is the left pedal). (If you hear a pedal moving but see no movement of the slave cylinder, you might calmly suggest she try the other left pedal.) While she's still holding the pedal down, unscrew the bleed nipple and let the air escape through the still connected tube to the bottle. Tighten the nipple again before she releases the pedal. Repeat this process until no air escapes when the bleeder nipple is opened. When finished, check and refill the reservoir as required.

Why doesn't the cap blow off?

Recall that the compressed air injected into the master cylinder can blow the reservoir cap off. One might ask: "Why doesn't the cap blow off when the pedal is pressed?"

There is a small hole at the back of the master cylinder that connects to the reservoir. When the pedal is out, fluid is free to flow from the reservoir through this hole into the cylinder and then through the output port and pipe/tube to the slave cylinder. When the pedal is pressed the small valve seal (part 9 in a previous sketch) is pressed against the little hole at the back of the cylinder closing the access to the reservoir. All fluid pushed by the piston as the pedal is pressed further must escape through the output port and then via the pipe and hose to the slave cylinder where it pushes the slave cylinder piston. Thus, the valve seal prevents pressure buildup in the reservoir.

How much should the operating arm move?

While under the car bleeding the system you might notice that the clutch operating arm doesn't move very far while the pedal moves a large distance from full out to full in. What is going on? This subject is addressed in the accompanying Clutch Calculation note. For a 0.75 inch master cylinder (TR250 & early TR6) one can expect the clevis pin in the center hole of the clutch operating arm to move about 0.6 inches when the pedal is pushed all the way in. This is for a system with relatively little wear. A system with substantial wear around the clevis pin between the pedal and master cylinder push will probably lose 10% or more of this motion. Air in the system will also degrade the system motion. For a 0.70 inch master cylinder (later TR6) one can expect the clevis pin in the center hole of the clutch operating arm to move about 0.55 inches when the pedal is pushed all the way in. This will degrade due to wear and air in the system in the same way as described for the 0.75 master cylinder.

How does one adjust the clutch?

A clutch should be adjusted so that the front of the release bearing is just about in contact with the clutch pressure plate when there is no pressure applied to the pedal. In mechanical systems there are adjustments on the levers or cables that must be changed from time to time as the clutch components wear. The Triumph hydraulic system adjusts itself each time it is used. After the pedal is released, the force from the clutch pressure plate springs push the release bearing back which in turn rotates the clutch-operating shaft and via the operating lever and push rod pushes the slave cylinder piston into the cylinder. The piston is held against the push rod by the spring behind the slave cylinder piston. Hence, there is no slack in the system after each use – completely self adjusting.

How much hydraulic fluid should the clutch use?

The system should consume very little fluid. Some small amount might be lost as a film is left on the side of the cylinders when the pistons move. If the system loses more than 1/4 of the reservoir in a summer, then you probably have a leak and the system is in the process of failing. Best get to work on it right away.

Insufficient Pedal

A typical clutch problem with TR6s is that it is difficult or impossible to shift into first or reverse gears. This is an indication that the clutch is not releasing when the clutch pedal is pressed. The system is more tolerant when shifting into the higher gears so the problem shows up initially with first and reverse.

This problem is nearly always the result of insufficient movement of the slave cylinder pushrod. Note that the self-adjusting feature described previously compensates for any slack between the slave cylinder and the clutch. Therefore, the problem is most likely between the clutch pedal and the slave cylinder. The first thing to do is to measure the travel of the clevis pin connecting the push rod to the clutch operating shaft arm --- it should be at least 1/2 inch. If the travel is 1/2 inch, then the problem is in the clutch components or the operating shaft or clutch fork.

If the clevis pin travel is less than 1/2 inch, then the following should be checked:

- Double check for air in the hydraulic system. I've found that even after bleeding the system, there is little margin but it seems to improve after a few hours use. I suspect a small air bubble in the master cylinder that eventually works its way out through the reservoir causes this problem.
- There may be slack in the area where the master cylinder push rod attaches to the pedal assembly. I've seen elongated holes and worn clevis pins that introduce 1/4 inch of slack --- that translates to 1/8 inch at the slave cylinder, enough to cause a problem.
- Also check the clutch pedal shaft bushings for slop.
- Check the slave cylinder mounting plate. One person noted that the plate on his TR250 flexed when the clutch pedal was pressed. He stiffened the plate and cured the problem.
- Check the hose feeding the slave cylinder. I understand some nonstandard replacements can't take the pressure and swell when the pressure is applied. If one has a hose not designed for the high pressure of this system it should be replaced before it fails and leaves you stranded.

If none of the above fixes the problem, one can remove the stop tab on the clutch pedal arm. This will give a little more pedal. Another alternative is to fasten the slave cylinder push rod to the upper rather than the middle hole in the clutch operating shaft arm. If none of these works, consider selling the piece of crap to your brother-in-law.