



## A Type Overdrive, Part III - Reassembly

Everything was disassembled and cleaned and the parts needed for the rebuild were determined in Part II. The reassembly is described in this part. The annulus was installed in the rear casting first. The clutches and epicyclic gears were dealt with next. The final step was to reassemble the hydraulic components in the main casting and then mate the rear casting to the main casting.

**Installing Annulus Head Bearing:** The annulus head bearing (or OD middle bearing) was pressed onto the annulus shaft until it was snug against the shoulder. A hydraulic press as shown in the photo on right was used.



Before installing the annulus in the rear casting, the distance between the bearing outer races was measured by driving the old head bearing into the rear casting and then measuring the distance from the outer race of the head bearing to the shoulder that the outer race of the tail bearing rests. This is a good use for a depth gauge. Lacking a real depth gauge, the part that slides out of a dial caliper was used as a depth gauge. Several measurements were taken until a repeatable result was obtained. The dial caliper was used again as a depth gauge to measure the distance from the head bearing inner race (just installed on the annulus shaft) to the shoulder on the annulus shaft that the adjustment washer rests. The difference between these two measurements is the ideal size of the adjustment washer. These measurements are not very precise so there will likely be some error. The size of the adjustment washer calculated from these measurements was used as a rough estimate.

**Installing Annulus in rear Casting:** The press was used to push the annulus into the rear casting. First, the rear adjustment washer was slid on the tail end of the annulus and then the annulus was fed into the rear casting. (There was no confusion as to which washer was the annulus adjustment washer and which was the washer under the nut, the adjustment washer has smooth sides and the one under the nut has gouges from the nut being tightened.) The tail bearing was then slid over the tail end of the annulus and into the end of the rear casting (the casting diameter is larger near the end to accommodate the rear seal, the bearing slides easily into the first half inch or so). The tail bearing was put in at this point to keep the shaft aligned during the pressing operation. Everything was then put in the press as shown on the right. Care was taken to assure that the head bearing was starting into the recess properly before applying heavy forces. Also, no more than the minimum force required to seat the bearing was applied to minimize any stress on the bearing.



**Installing Annulus tail Bearing:** A large thrust washer (originally from a gearbox) was placed over the end of shaft and against the side of the bearing and a pipe coupling spacer was slid over the shaft as shown in the photo on the right. This is the same as the previous setup except the annulus is being pressed into the tail bearing instead of the rear casting. The press force was limited to that necessary to get the bearing seated.

The rear flange was then slipped on the shaft followed by washer and nut. Note that the rear seal was not installed yet. The nut was tightened to ~ 100 foot pounds using the same flange retaining bar discussed in Part II and then the rear flange was bolted to the OD stand.



**Measuring Annulus End Float:** The annulus end float was measured again using the same procedure described in Part II. The dial indicator tip was positioned against the annulus. The casting was then pushed down and a first reading taken. A second reading was taken after the casting had been pulled up by placing our hands on each side of the casting and pushing down on the annulus with our thumbs. The difference between the two readings is the end float. The end float was within the .005 to .010 inch specification before the unit was disassembled so it was expected to be within specifications after reassembly, even with new bearings. In this case it was. If it were not, one of the bearings might not be seated. The first thing I'd try is to use a punch to drive the tail bearing outer race a little further into the rear casting. The next most likely problem is that the head bearing inner race isn't seated against the annulus shoulder. One might have to go back to the first step above to make sure the head bearing is seated properly. Another possibility is that the old bearings were worn and sloppy. If the bearings are seated properly and the end float is still out of specs, read on.



**Annulus End Float Out of Specifications:** The sectional view on the right is part of a diagram in the Service Instruction Manual mentioned in Part I. Component 14 is the Annulus, 21 and 25 are the head and tail bearings, 24 is the adjustment washer and 26 is the rear seal.

New head and tail bearings have some end float between the inner and outer races. I don't have specifications on the bearings but expect it is about .010 inch. Note from the sketch above that the outer races on the two bearings are pressed against shoulders in the rear casting. The inner races are squeezed together by the annulus head and the rear flange. The adjustment washer (24) rests against a shoulder on the shaft and keeps the inner races apart

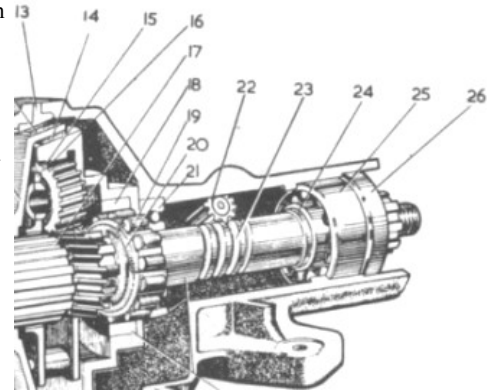

If everything is perfect, the distance between the two outer races is exactly equal to the distance between the two inner races and the annulus end float will be equal to the lesser of the two bearing end floats. On the other hand, if the distances between the two inner races and the two outer races are different, the end float will be less. In the extreme, if the difference in these two measurements is too large, there will be no annulus end float and the bearings may have a pre load ---- a lateral force applied to the bearings. Pre load will likely lead to early bearing failure.

If the end float is out of specifications, it can be too large or too small. If it is too large, then there is probably too much end float in both bearings, they are probably very sloppy (possibly caused by an incorrect adjustment washer) and need replaced.

If there is too little end float, then a different adjustment washer can be used to get the distance between the inner races to match the distance between the outer races. Washers are available (or were available 30 years ago) in .005 inch increments between .146 and .181 inches. Lets say that the end float is .002 inches. The next size washer should bring the end float to .007 inches, in the middle of the specs. Should a thicker or thinner washer be used? You can't tell from these data. If one has a stack of washers, a thicker one and then a thinner one can be tried, etc. There are 8 washer sizes and if one starts with no end float, this can take some time. There is a factory tool that allows one to measure the distance between the inner and out races and compute the correct size washer. I don't happen to have that tool and it looks like too much work to make one to use it once in a lifetime.

Since this unit worked at one time, it is hoped that the original adjustment washer was close to the right size. There is of course the possibility the worker that originally assembled the unit had been up all night watching football (soccer) on the telly or had too much Guinness for lunch. The TRs are notorious for having incorrect parts installed by the DPO or his mechanic. Since the adjustment washer is relatively hard to get at, this is unlikely, but not impossible.

Data was collected before the rear casting was assembled and a rough estimated of the correct washer thickness was calculated. This is a substitute for the factory tool. That estimate together with the actual size of the adjustment washer can be compared to estimate whether a thicker or thinner washer is needed.

To determine the correct size washer I would shim either the outer or inner race of the tail bearing. Suitable .005 inch steel shim stock can be obtained from the local machine shop or machine shop supplier. Another source is McMaster Carr (see links page).

If the adjustment washer is thought to be too thin, I'd cut a washer out of the shim stock the same size as the adjustment washer and add it beside the adjustment washer. If the end float increases, it is clear that a thicker washer is required. If there was no end float to begin with, I'd start with enough thickness to match the estimated washer size. Consider following examples:

If the original end float was .003 inch and a .005 inch shim was added and the end float increased to measured .008 inch, an adjustment washer .005 inch thicker is required.

If the original end float was .003 inch and a .005 inch shim was added and the end float decreased to zero, then a .005 inch thinner adjustment washer is required.

If the original end float was zero and a .010 inch shim was added and the end float increased to .006 inch, then a .010 inch thicker adjustment washer is required.

If the original end float was zero and a .015 inch shim was added and the end float increased to .002 inch, then a washer either .010 or .020 thicker adjustment is required.

If a thinner washer is required, I'd cut a .005 shim washer the same size as the tail bearing outer race and insert it between the outer race and the shoulder on the rear casting. I'd use the same procedure as above to determine the correct thickness of shim to start with. In this case, the thickness of shim is the amount *smaller* the adjustment washer should be.

Once the annulus is shimmed so that the end float is correct, the exact size of the adjustment washer is known. However, why not just leave the shim(s) in place rather than trying to secure a different size adjustment washer? I wouldn't have any problem with leaving steel shims between the adjustment washer and the tail bearing. I don't think I'd leave shims behind the outside bearing race because the shoulder in the rear casting is narrow and the shim might work out. The shims behind the outer race are used because the adjustment washer is too thick. I'd probably try to remove some material from the washer. Assuming that the washer is not hardened, I'd put it on my little mill and remove the required material. One could probably also use a file if only a small amount need removed.

**Installing Rear Seal:** After the adjustment washer was installed and the end float found in spec, the shaft was rotated to make sure it turned smoothly and freely. The rear flange was then removed and the rear seal installed. An ounce or so of oil was poured over the rear bearing to make sure it was lubricated at startup. A small amount of grease was spread around the outside of the seal and also on the inner lip. The seal was inserted lip forward and tapped into place using a punch. The front of the seal rests against a shoulder in the casting as shown in the previous sectional drawing. That is the current owner of the OD (undoubtedly someday to be unjustly know as the DPO) busy at work. Don't you love his shirt?

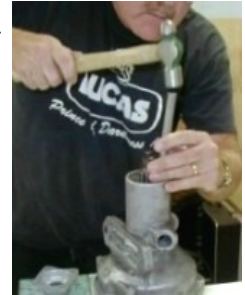

The rear flange was installed again. This time a little gasket sealer was put under the washer to prevent oil leaking along the splines and past the washer. The nut was tightened to ~ 100 foot pounds and then turned on to the next slot for the cotter pin. After everything was together, the shaft was rotated again to make sure it turned smoothly and freely.

**Installing the Speedometer Gear:** The speedometer bearing with gear was inserted and rotated until the hole in the bearing aligned with the hole for the locking screw hole. The locking screw was then inserted and tightened.

**Washers:** There are a total of 6 washers that fit over the mainshaft and annulus shaft. Each washer was carefully bagged with the associated parts so that they wouldn't get mixed up. However, along the way they got all mixed up. No reason to panic, they are all different and easy to tell apart. The three washers shown below all go on the mainshaft. The left washer is the bronze thrust washer that goes between the unidirectional clutch and the annulus. The center washer is the bronze thrust washer that goes between the sun gear and the main casting. The right steel washer is the adjustment washer that also goes between the sun gear and the main casting. Note that the left thrust washer is much wider with a smaller ID. The right two washers have the same ID & OD. There is one more thrust washer that fits and is held inside the planet gear carrier. It is easy to identify because the edges on one side are beveled. The two steel washers that fit on the annulus can be differentiated from the right adjustment washer in the photo because they have a slightly larger ID; the right adjustment washer in the photo is too small to slide on the annulus shaft. (Sorry that I forgot to take a photo of all six washers together; when I thought of it the other three were already in place and I was not about to take them out.)



**Assembling the Unidirectional Clutch:** The parts of the unidirectional clutch in the left photo below are inner member (upper left), cage, spring, thrust washer and rollers. The spring was connected to the inner member first as shown in the middle photo. There are two ways to connect the spring, only one is correct. Next, the other end of the spring was slipped into the hole in the cage, followed by the inner member. The inner member was then rotated against the spring and locked into place by the cage tabs shown in the right photo. The end of the spring can be seen sticking out of the cage in the right photo.



The 12 rollers must be inserted into the cage next. One way to do this is to wrap a heavy rubber band around the cage and then lift it and feed the rollers into position one at a time. The manuals show photos of a Churchill tool to help assemble the clutch. A similar tool was fabricated using a plastic pipe coupling and bushing as shown in left photo below. The inside was turned to a diameter just less than the inner diameter of the recess for the clutch in the annulus and to a depth slightly less than the clutch thickness. The slot in the side is just wide enough for a roller to pass. The cage with inner member is placed in the tool as shown in the middle photo and the rollers fed into the cage. The inner member is rotated clockwise after each roller is inserted. If an attempt is made to turn the inner member counterclockwise, the clutch will lock. (If it doesn't lock, then the ramps are probably not positioned as shown in photo and it must be taken apart and reassembled, making sure the spring is installed in the correct direction.) The assembled clutch is shown in the right photo.



**Installing the unidirectional Clutch:** The rear casting was still mounted to the OD stand. The thrust washer was positioned (left photo), the tool with clutch inside was placed over the recess and the clutch pushed into the recess (center photo), and the tool lifted away (right photo). If one used rubber bands to assemble the clutch, then the procedure is the same and the rubber band would slip off as the clutch was pushed into the recess.



**Dummy Mainshaft:** Several of the procedures require the use of the mainshaft or a suitable fake. If one has the mainshaft out of the gearbox or has a spare, great! The gearbox for this project had already been assembled so I took measurements from the part protruding from the rear of the gearbox and turned a shaft of the same diameter from scrap mild steel. A slot was milled in the shaft and one spline installed to aid later in aligning the unidirectional clutch and the planet carrier. While installing a clutch several days later using a plastic dummy mainshaft I thought --- why didn't I make this dummy mainshaft from plastic or nylon, etc --- it would have taken one tenth the time. Suitable materials are available from McMaster-Carr. A wood dummy should also work fine.



**Testing the Unidirectional Clutch:** Before proceeding the clutch was tested by inserting the dummy mainshaft in the clutch and rotated in both in both the clockwise and counter clockwise. (If a shaft wasn't available, one could have done the same thing by using fingers to push the top of the cage). Everything was working properly, the clutch rotated easily in the counterclockwise direction and locked to the annulus when clockwise rotation was attempted. If it didn't do this, then the clutch was assembled backwards and would have to be pulled out and reassembled. After everything checked out OK, an ounce or so of oil was poured over the unidirectional clutch and also between the annulus and the rear casting.

**Planet Carrier:** Each of the planet gears was rotated to make sure the bearings were smooth. Normally there will be no problem and nothing else need be done to the planet carrier. In this case the mainshaft thrust washer retained in the center of the planet carrier was destroyed and the new washer couldn't be installed without removing one of the gears. The photo on the right shows a gear, the little shaft and associated tabbed thrust washer. There is a hole in the top of the shaft. A 3/32 mild steel pin is driven through a matching hole in the carrier and into this hole to retain the shaft. The pin was drilled out using a 5/64 bit.



The shaft was tapped out with a hammer and punch and the gear and washer removed. (If it was necessary to replace the planet gear bearings, this procedure would have been followed to remove the gears. There are two roller bearing cages pressed into the gears. These would be pressed out and new ones pressed in. These bearings weren't removed this time for fear they might be damaged and spares weren't in hand.)

The thrust washer was positioned in the recess in the center of the carrier. The top of the washer is beveled to provide clearance for the planet gear teeth. (If the top of washer isn't beveled, one can try turning it over.) The planet gear thrust washer was then positioned with the tab in the hole, the gear slid into position and the shaft tapped home using a small hammer. The photo on the right shows a drill bit in the hole in the shaft to help keep it visually aligned with the hole in the carrier. A 3/32 steel retaining pin didn't seem tight enough so a 3/4 inch long 3/32 expansion pin was ground down to a length of ~.6 inches and used instead. The expansion pin is tempered and will likely ruin a drill bit if one tries to drill it out. However, if the shaft is pressed out, the pin will shear off and the pieces can then be tapped out with a small punch. (I tried it to make sure it works.)



**Installing Epicyclic Gear:** The sun gear can be installed in the planet carrier with the planet gears in various positions. If the gears are not in the correct position, the sun gear shaft will be off center. This would be recognized when it was impossible to pass the mainshaft through the sun gear, the planet carrier and the unidirectional clutch. There are indexing dots stamped into the top of each of the planet gears. Each gear was turned so that the dot is on the outside and a line through the dot and the center of the planet gear shaft also passed through the center of the planet carrier as show in the left photo below. The sun gear was inserted with the planet gears aligned as indicated. The dot alignment was verified after the sun gear

was in position. The three dots didn't line up as indicated, so I did it over and got it right. The planet carrier with sun gear was then inserted into the annulus. The sun gear was rotated back and forth slightly to get the gears to mesh properly so that the planet carrier would drop into the annulus..



**Measuring Sun Gear End Float:** A thrust washer and adjustment washer fit between the sun gear and the bushing in the rear of the main casting (left photo below). When everything is put together, the sun gear must have an end float of between .014 and .020 inches. The books tell you to put an extra washer (thickness over .025 inches) on the mainshaft, pound the brake ring in the main casting and slide the main casting into position. Because of the extra washer, there will be a gap between the brake ring and the rear casting. Measure that gap with feeler gauges and subtract the measured value from the size of the extra washer to determine the end float. For example if the gap is .025 inch and the washer is .040, the end float is .015 inch. I was unable to get a repeatable measurement using this method --- the brake ring was on crooked, slid down from the main casting, or main casting tilted, etc.

The method used to measure the annulus end float with the dial indicator worked well so a way was found to do something similar here. Unfortunately, it's six inches or so between the only surface on the sun gear one can position the indicator point and the body of the indicator. Point extenders are available, but not in this workshop. Instead, a piece of square brass tube (available at hobby stores) was used as an extension. The scheme was to install the two washers (no extra washer this time) and then slide the main casting with brake ring into position. The two castings went together with the brake ring in-between. Nuts were tightened on a couple studs on opposite sides of the case to make sure everything was seated. I was able to reach through the gap in the main casting and feel the sun gear shaft, rotate it and try to feel some end play -- but found none. Next, one end of the brass tube was positioned on one of the sun gear teeth and the other end slipped under the dial indicator point. A couple hooked tools were then used to lift the sun gear up. The change in the indicator reading was the end float. The center photo below shows where the rod and hooked tools were positioned and the right photo shows the lifting tools; a scribe and a screwdriver with a bent tip (also used to install door top weather seal clips).

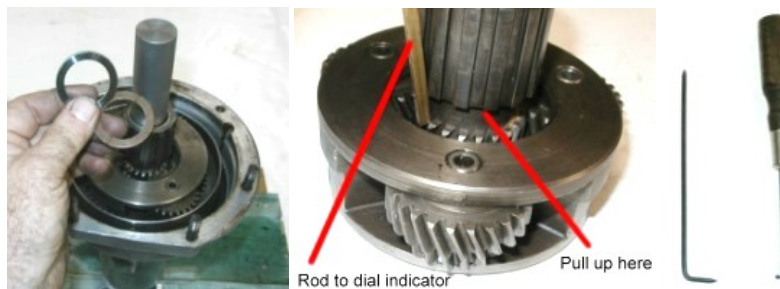

The left photo below shows the actual setup. A fairly large steel bar was used to secure the indicator magnetic base and provide stability. The right photo shows a young LBC mechanic wannabe at work.



**No End Float!** When the end float was measured with the dial indicator there was none. That was the same result I got using the extra washer method --- but the problems mentioned earlier caused variations of about .010 inch so I didn't know for sure. A problem was suspected because the thrust washer had a groove worn in it. Also, remember that the thrust washer between the sun gear and planet carrier had been destroyed.

Closer examination of the trust washer and sun gear revealed that the bushing pressed into the sun gear was not flush with the top of the gear --- it stuck up at least .010 inches. This bushing has a steel outside and brass or bronze inside. The steel outside part had cut a groove in the thrust washer as shown in photo on right. An attempt was made to press the bushing in further --- wouldn't budge. The protruding part was then filed off smooth. (Photo is after it was filed.) The thrust washer groove was positioned away from the sun gear in the earlier measurements, which explains the lack of end float.



After filing off that ridge, everything was put together to measure the end float again ---- it was about .012 inches this time. Still a little short. There was no hurry this time (I was waiting for a motor to arrive for a test stand --- see next part) so the next size smaller adjustment washer was ordered. A replacement for the damaged thrust washer had been purchased when parts were ordered parts earlier. Unfortunately, I couldn't find the damn thing. Maybe the workshop cats ate it -- or the mice carried it off. The rough edge around the groove in the old washer was filed smooth and the washer was positioned with the groove against the adjustment washer --- should work fine. That new washer was found later and installed when other problems were encountered necessitating disassembly again as discussed Part IV.

Why no end float to begin with? Could this have anything to do with the failure of the thrust washer between the sun gear and planet carrier? Could this have caused the thrust bearing to fail? Note that the thrust bearing slides over the shaft on the sun gear. One possibility is that the thrust washer failed first and a piece of it got in the thrust bearing causing it to fail. Why wasn't the lack of end float and the problem with the end of the sun gear found at the factory --- British Quality? Maybe half the parts have been replaced by some PO in this baby's 40 year life. We'll never know.

**Assembling the Sliding Clutch:** This job as illustrated in the photos below was fairly straightforward. The outer race was driven into the thrust ring and then the circlip installed. This circlip is a biggie and takes a lot of force to compress to get it into position. We made sure the circlip was fully seated. Next, the thrust ring with bearing was placed over the clutch sliding member and the inner race driven onto the sliding member. The final step was to install the inner race circlip. Fred Thomas (the young man who helped me get started powder coating) had his TR3 OD quit and when disassembled the only problem found was that the circlip had come out. It was reinstalled and the OD tested and found to work fine. Message: **make sure the circlips are seated!**



**Installing the Operating Valve:** The main casting was assembled next. The operating valve parts are shown in photo below. Before installing the valve, a little oil was poured into the area of the main casting housing the valve. The valve spindle (the long shaft) was installed first, then the ball, followed by the spring with the plunger inside. The plug, with copper washer was then fed over the spring and screwed down. Torque specs for the plug were not available but the case is aluminum so one shouldn't go too tight. On the other hand, there is ~ 450 psi and one doesn't want a leak. I decided to use 20 foot pounds and see if it leaked. The valve was tested by operating and releasing the lever on the outside of the case beside the valve. The spring pushed the the lever back when it is released as it should.



**Installing the pump:** The next step was to press the pump into the main case. The ends of two 2 inch long 3/16 steel rods were threaded 12-32. These rods were then screwed into the pump retaining screw holes to guide the pump housing into the correct position (left photo below). The rod used to extract the pump was then screwed back into the pump. Both the inside and outside of the pump body were lubricated, the spring slipped on the piston and the piston with spring slipped into the pump body. The end of the piston is asymmetric as seen in the middle photo. The thin side is positioned next to and slides beside the steel pin in the main casting. The pump with piston was slid into position over the pins. Before pressing the body in, the thin side of the top was verified to be next to that pin and the hole in the pump body was on the correct side to match up with the hole for the non-return valve. After everything was positioned correctly, the pump home was driven home using a hammer on the end of the threaded rod. The large threaded rod and two smaller rods were then removed. A little oil was poured into the pump housing and then the plug was installed followed by the two small screws. The screen filter was installed next, and then the drain plug with a new washer/gasket. This OD didn't have the magnets under the filter that are used on the later ODs.



**Installing the Accumulator Piston:** The threaded rod used to remove the older style accumulator piston was screwed back into the piston and the piston and cylinder in the main casting were thoroughly lubricated and a little extra oil poured into the accumulator cylinder. The threaded rod was then used to position and press the piston back into the main casting. Care was taken to not damage the rings in this process. The threaded rod was removed after the accumulator was in position. If the later style accumulator were used, the piston would be carefully inserted into the housing from the top end (the book says don't insert through the bottom with the conical recess because the rings may scrape the aluminum when entering the the housing). The removal tool would then be attached to the housing and used to insert the housing with piston.

**Installing Accumulator Spring(s) & Cover:** The two accumulator springs were inserted into the accumulator piston. (If the accumulator was the later type, it would have been one spring and the spring tube.) Both sides of the cover plate gasket were coated with sealer, the gasket was positioned between the cover plate and the main casting and then the sealing O ring was placed on the operating valve shaft. The cover plate was then drawn down using the two long bolts, alternating tightening each a few turns to keep the cover square as it compressed the spring. When the cover plate started to slide over the two studs, it was tapped it in the area of the studs to make sure it wasn't hanging up on the studs. After the two bolts were tight, the dust shield and lock washers were slipped on the studs followed by the nuts. Mounting the actuating lever and solenoid was deferred until after the unit was tested.



**Installing the Pump Non-Return Valve:** The pump non-return valve is identical the the operating valve installed earlier except there is no long spindle. The parts were lubricated and then the ball, plunger and spring were dropped into the hole. The plug with copper washer was then screwed in and tightened.

**Mating the two castings:** The sliding clutch was positioned over the sun gear shaft on the rear casting that was still mounted to the OD stand. A small amount of sealer was spread on the surface of the brake ring that mates with the rear casting and the ring was driven home with a hammer and punch (left photo below). A small amount of sealer was then spread on the surface of the brake ring that mates with the main casting. The dummy mainshaft was still in place and the thrust washer and adjustment washer in front of the sun gear were still in position. The main casting was then positioned on the rear casting/brake ring with the four threaded end thrust ring rods going through the holes in the main casting. The main casting was tapped into position (wood block & hammer) and drawn tight with six nuts and lock washers on the studs. The center photo below shows the two castings in position. Some sealer may ooze out after everything is tightened. The Hylomar sealer stays sticky for weeks and makes a big mess. The excess was removed using a paper towel dampened with mineral spirits. The last thing was to position the two bridge pieces on the thrust ring rods and secured them with nyloc nuts (right photo).



**Preliminary Test:** Prior to installing the OD on the gearbox a test was run using compressed air to make sure the valves and pistons were working. An adaptor with 1/4 pipe threads on one end and a plug for the operating valve on the other (top photo) was made. This adaptor was used first for injecting air into the hydraulic system and later for a gauge to measure the hydraulic pressure. The adaptor was made such that the operating valve spring, plunger & ball were positioned properly and the valve operated with the adaptor in place. A damaged operating valve plug and a 1/8 inch pipe tap were available to do the job. The first plan was to drill and tap the plug for a 1/8 inch pipe nipple. Unfortunately, the 1/8 inch pipe thread was nearly 0.4 inches in diameter and the plug head was a 7/16 inch hex --- insufficient clearance. Instead, the plug was drilled and tapped 1/4-28. Next, an adapter from 1/4-28 to 1/8 inch pipe threads was made from a 1/2 inch bolt. The length of the 1/4 inch part threaded into the operating valve plug was such that depth of the recess in the plug for the valve spring was unchanged. A 3/32 hole was drilled through the adaptor for fluid flow. A 1/8 inch nipple and a 1/4 inch to 1/8 inch reducer completed the setup. The nipple was of sufficient length so when later used with the gauge, the gauge was above the gearbox top cover so that it could be installed and removed easily.



### A Type OD Part III

Next, the eight springs were installed over the rods on the the thrust ring as shown in the middle photo. The long springs go on the outside and the short ones on the inside. A couple holes were drilled in a plywood scrap and it was bolted it to the front of the OD to simulated the adaptor plate, compressing the 8 springs in the process (bottom photo). The air line was connected and the lever below the operating valve plug was pushed down. There was an audible clunk as the clutch shifted into OD and a slow air escaping sound when it returned to direct drive.



In direct drive, the output flange rotated easily in either direction. In OD, the 1:1.2 step up between the input and output was observed for clockwise rotation (as viewed from the front). The output couldn't be rotated in the counterclockwise rotation as expected. This is the easiest way to tell that the OD is engaged --- it wouldn't rotate counterclockwise (recall that the OD must not be engaged in reverse).



For this system, something around 100 psi was required to operate the clutch. If the clutch hadn't operated with the available air pressure, the nuts holding the plywood board would have been loosened to reduce the spring force to see if it would switch then.

If there had been a hissing sound from air escaping inside the unit the unit would have then been examined for the source of leaks, starting with the operating valve and non-return valves as discussed in Part V.

**We finish the assembly and test everything in the Part IV.**